

CARLINGA DE APOIO NO ENCONTRO 2  
ESC=1:50

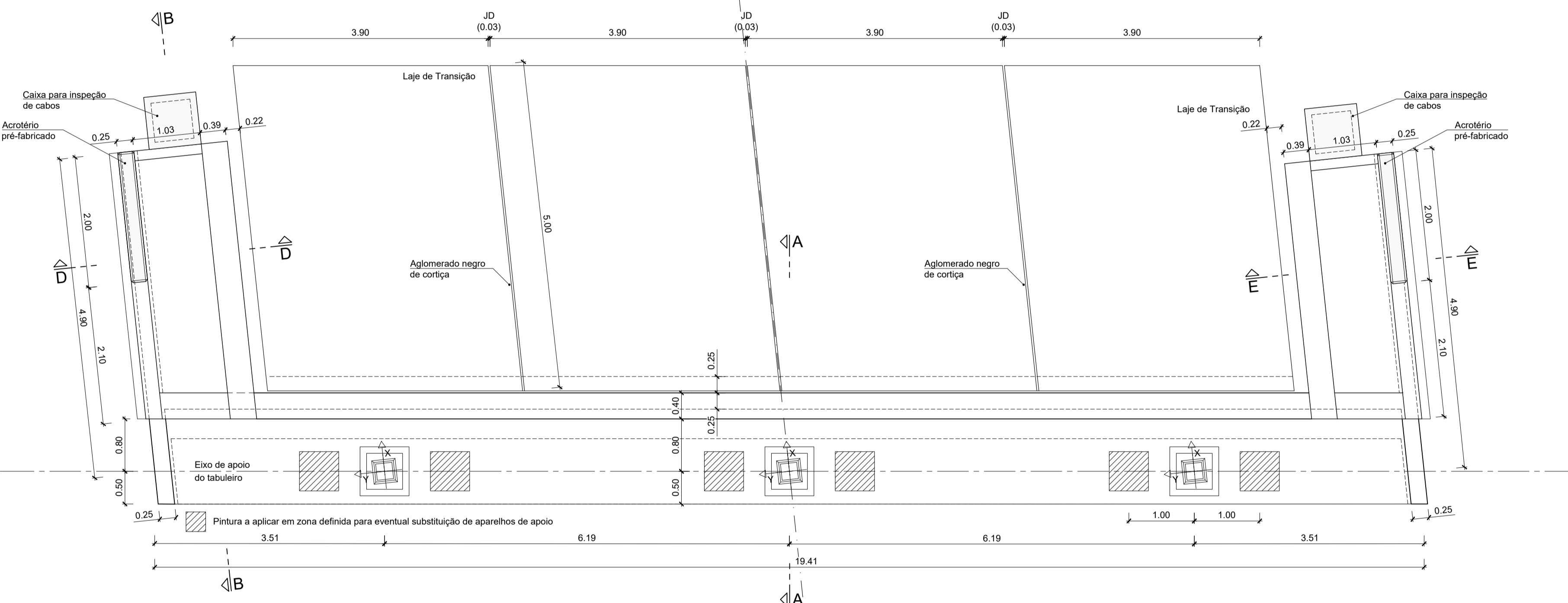

PLANTA  
ESC=1:50

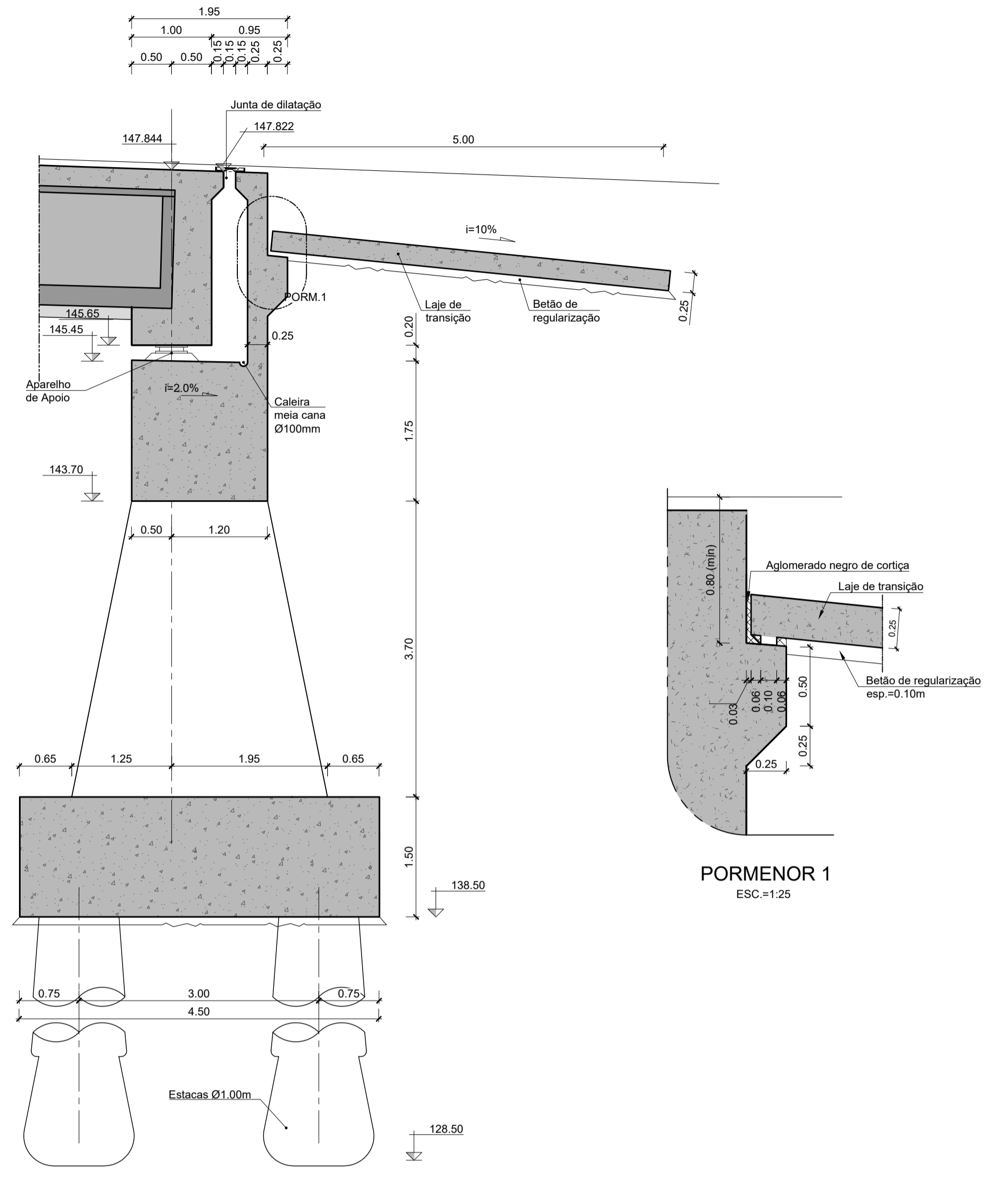

CORTE A-A  
ESC=1:50

PORMENOR 1  
ESC=1:25

PARÂMETROS DOS APARELHOS DE APOIO, DO TIPO PANEIS UNIDIRECCIONAIS

	ELU	ELS
N.max. (kN)	3700	2650
N.min. (kN)	20	225
Vx.n_max (kN)	--	--
Vy.n_max (kN)	510	165
Nv_max (kN)	1100	2650
Vx.max. (kN)	--	--
Vy.max. (kN)	2800	450
δx.max* (mm)	150	20
δy.max* (mm)	--	--
θy.max (rad)	0,0018	0,0010
N.ações_perm. (kN)	1250	

NOTAS:  
1 - ELEMENTOS EXTRAÍDOS DO CÁLCULO.  
2 - VALORES POR APARELHO DE APOIO.  
\* - VALOR COMPATÍVEL COM A JUNTA PROJETADA ± 150mm

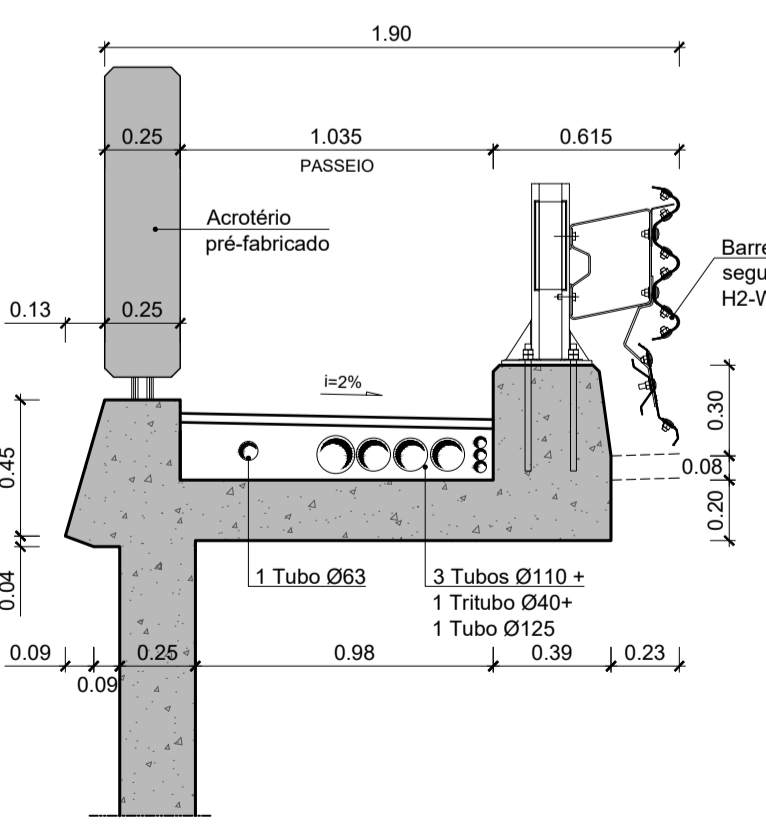

CORTE D-D  
ESC=1:25

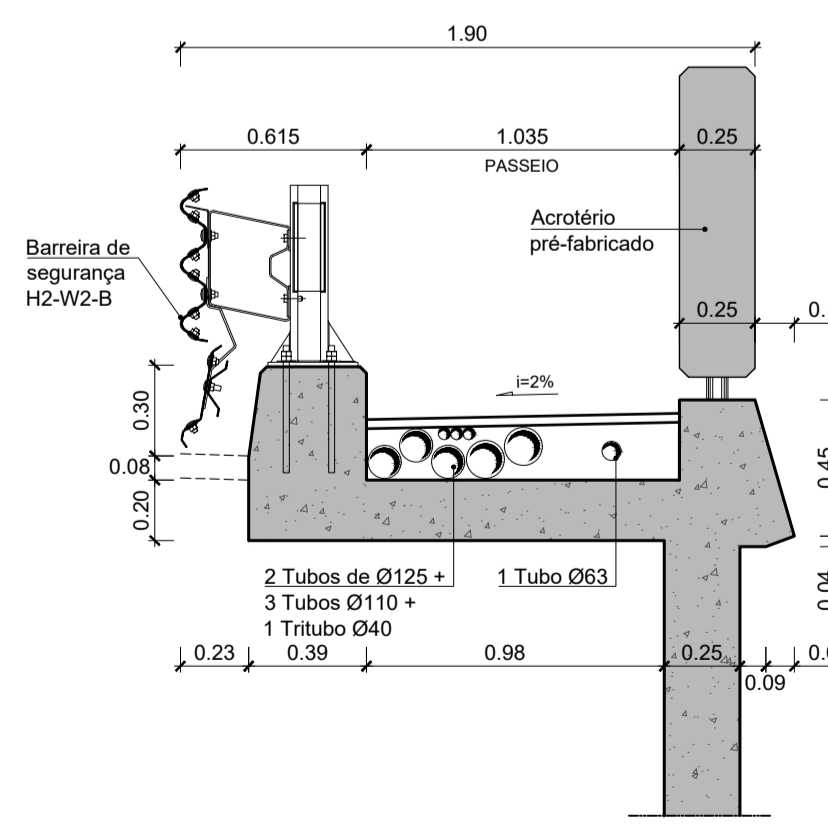

CORTE E-E  
ESC=1:25

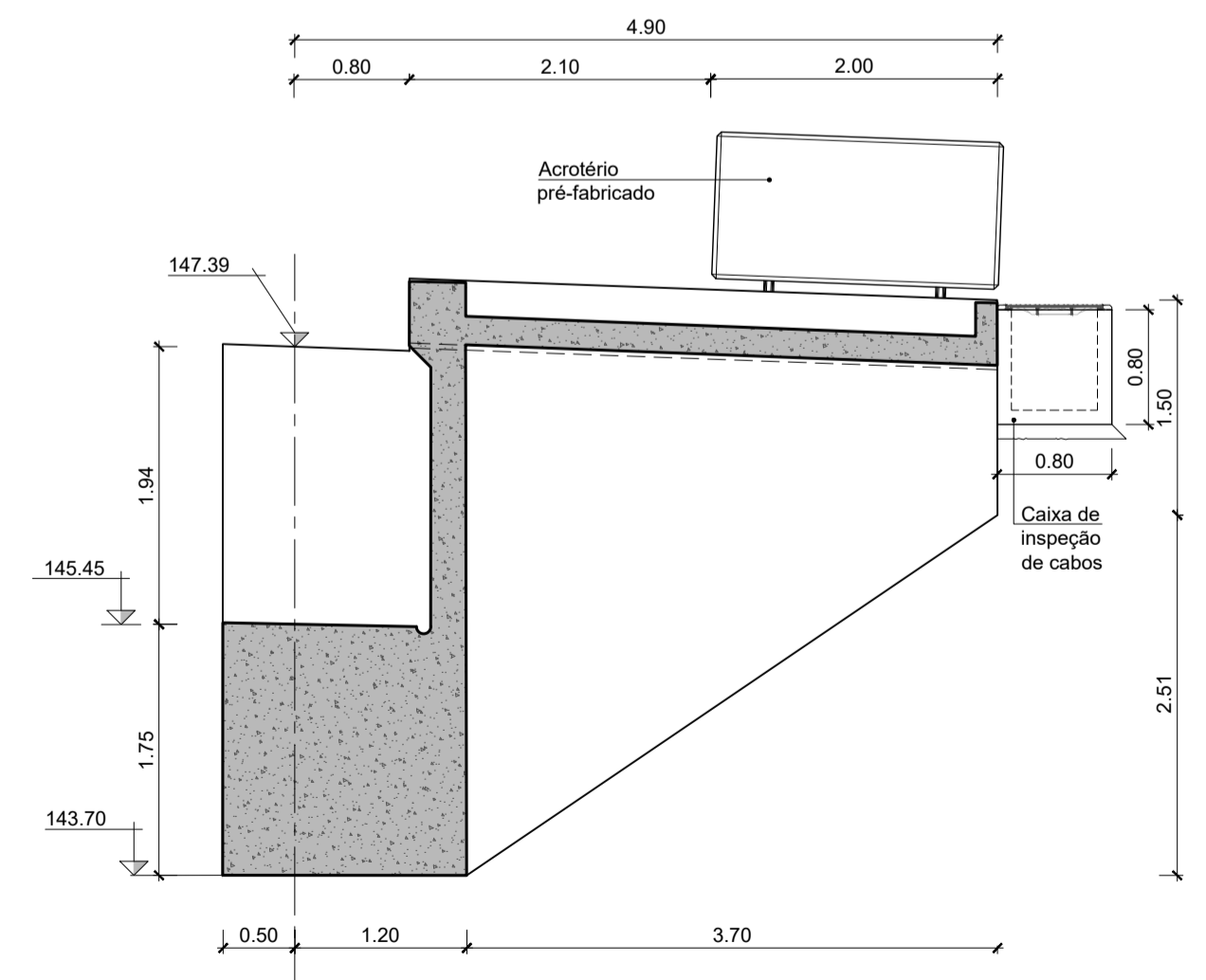

CORTE B-B  
ESC=1:50