

DATA IMPRESSÃO: 14-mai-2020
 \PPL\PLANS\PPL\PLANS\UTILIZADORES\DESENHO\REFPREFESA - JOBS - 50'S\JOB-18040 - RECKITT - SUPORTES\TELAS FINIS - SUPORTES ANTI-SISMICOS\J-18040-BIA01-TF.DWG

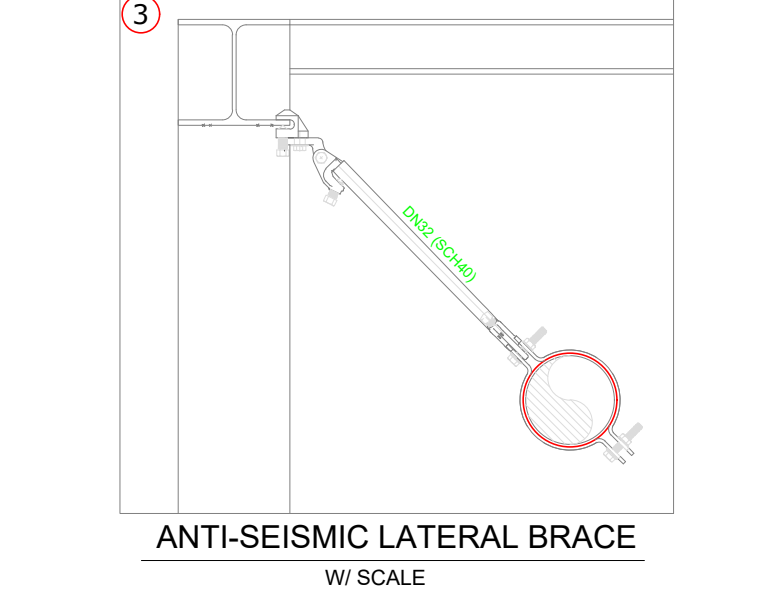
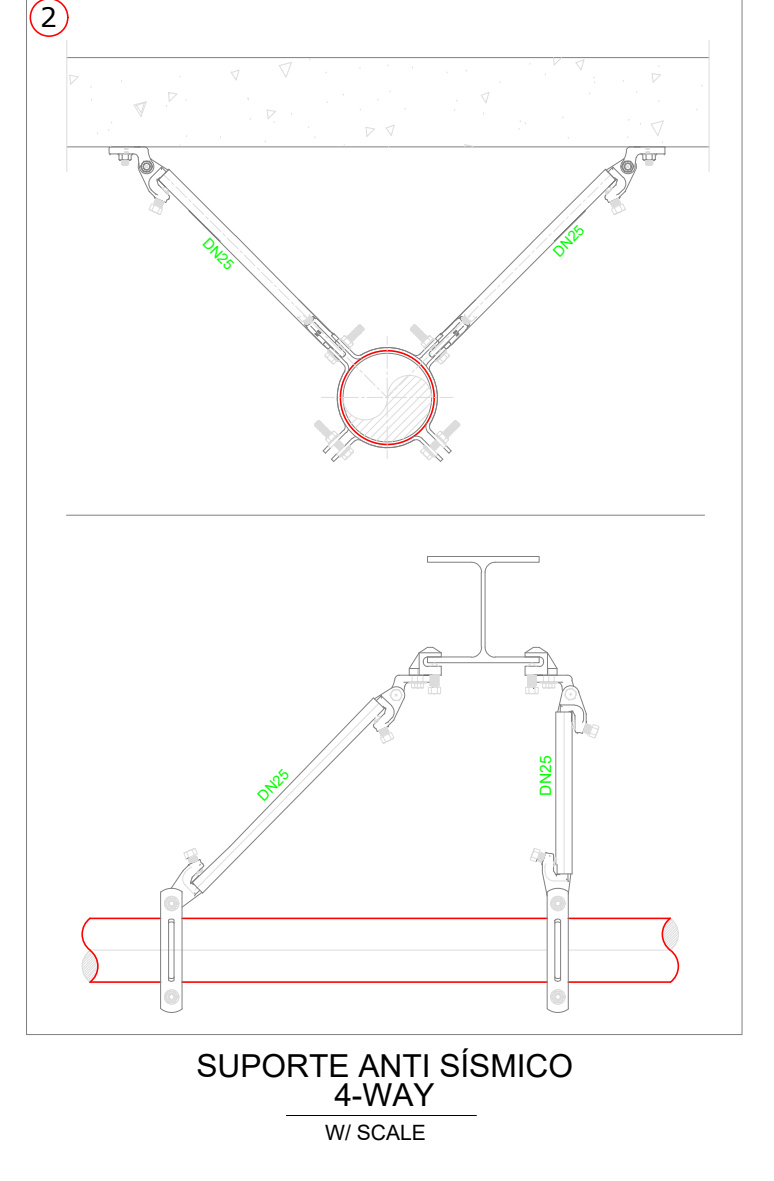
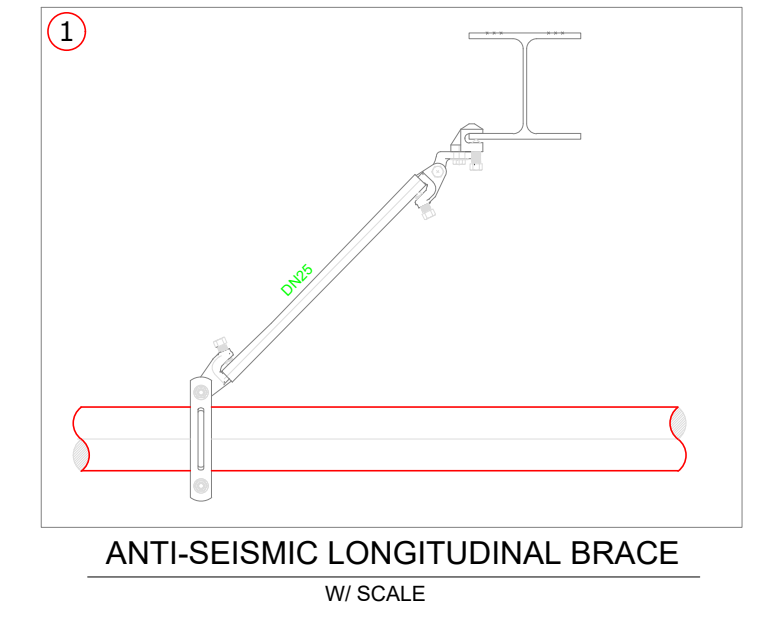
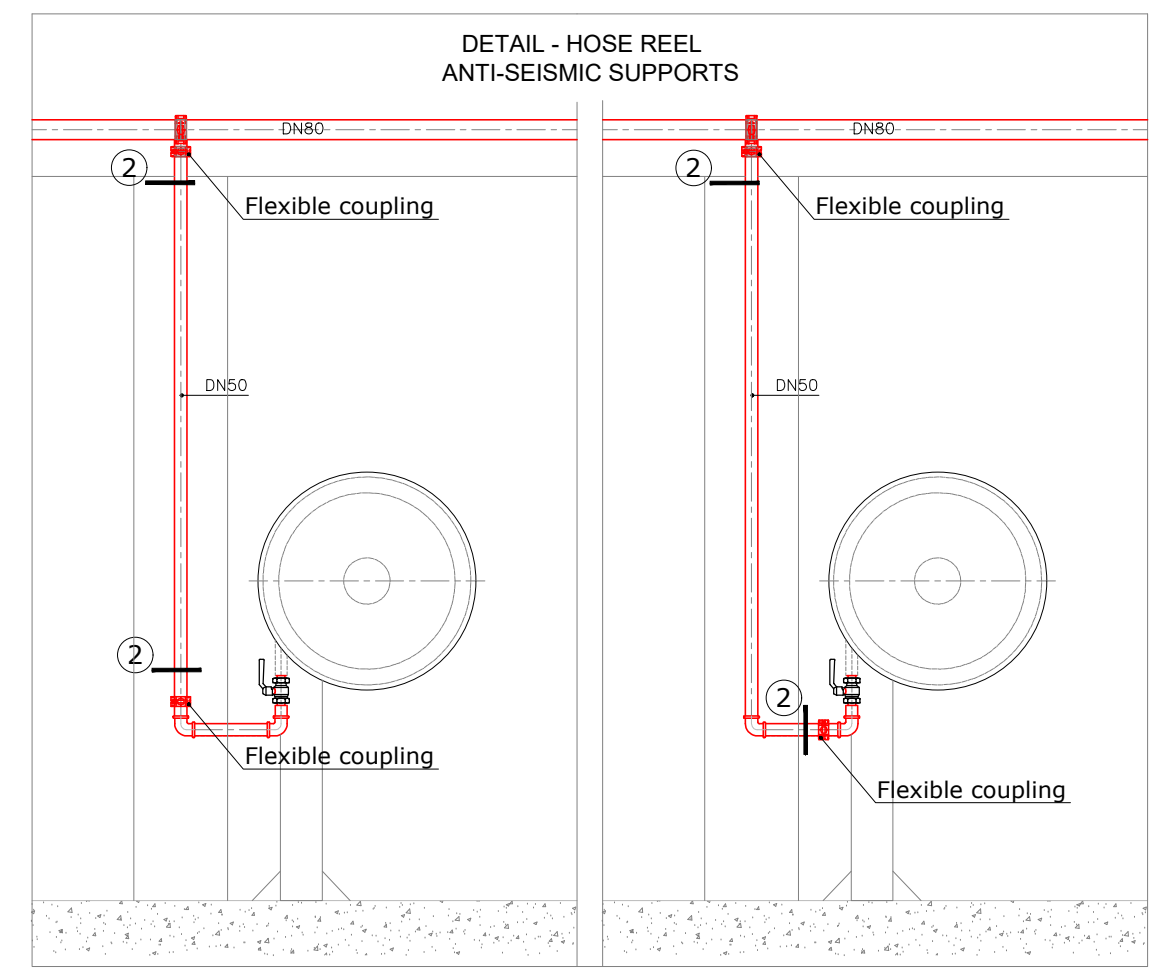
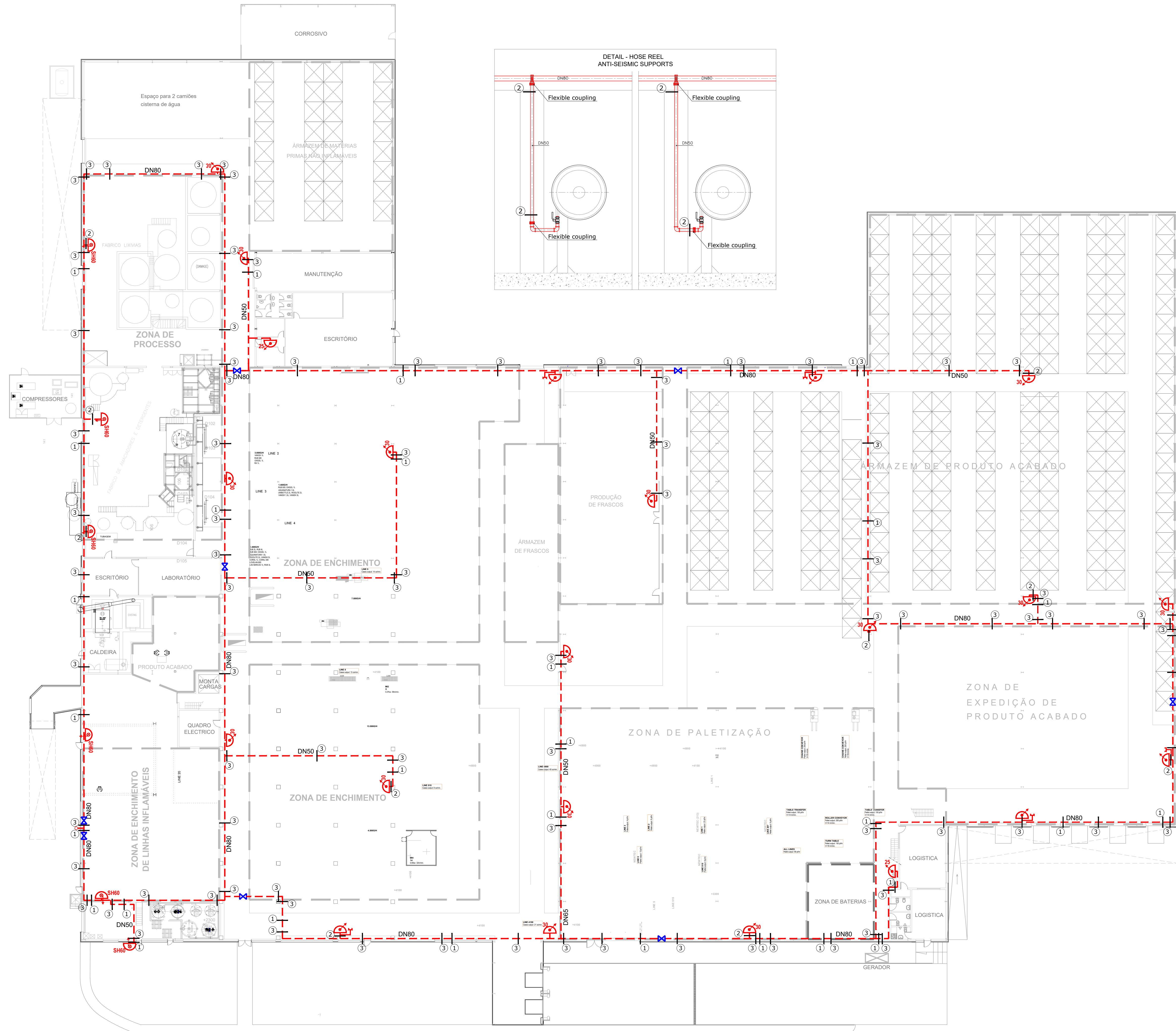

- LEGEND:**
- INDUSTRIAL HOSE REEL 1 1/2"
 - HOSE REEL 1"
 - INDUSTRIAL HOSE REEL 1 1/2" WITH STORZ
 - FOAM HOSE REEL MINIMAX SH60
 - HOSE REEL PIPE
 - BUTTERFLY VALVE

TF	05.07.19	FINAL SHEET - ANTI-SEISMIC SUPPORTS	Luis Costa	J. Branco
REV. EDIT.	DATE	DENOMINAÇÃO / DENOMINATION	DES. DWGN	APPROV. APPRD
pefipresa		Av. Pedro Álvares Cabral, 213 2710-297 Sintra - Portugal Tel.: 214647410 - Fax: 214647420 E-mail: info.lisboa@pefipresa.pt		
DELEGAÇÕES:		A Coruña 981 78 00 82 Barcelona 93 383 97 24		
		Bilbao 944 83 00 10 Madrid 91 710 00 00		
		Lisboa 965 96 46 24 Portugal 351214647410		
		Sevilla 95 471 47 28 Valencia 96 136 61 23		
CLIENTE	CLIENT	PLANO N / DWG N	J-18040-BIA01-TF	
		FOLHA / SHEET	DE / OF	1 / 1
DENOMINAÇÃO		ESCALA / ESCALE	1:250	
DENOMINATION		FIRE PROTECTION FINISH PRODUCT - FLOOR PLAN HOSE REELS NETWORK		
Este documento é propriedade da Pefipresa e proíbe a reprodução total ou parcial sem o devido autorizações				